

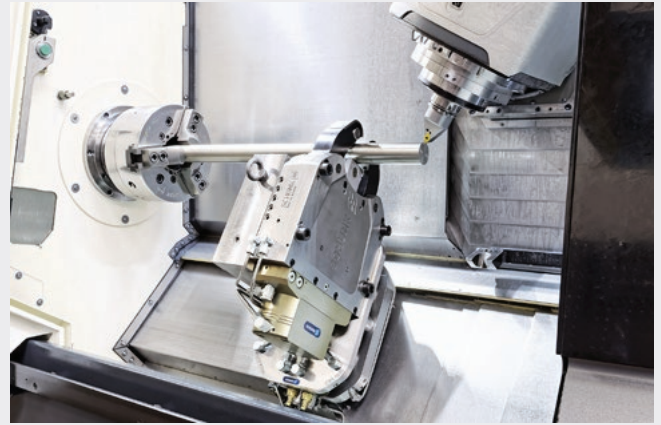

ZENTRICO THL plus
Self-centering steady rests
with rear cylinder

Self-centering steady rests with high clamping forces and excellent centering and repeat accuracies

Hydraulically actuated, self-centering steady rests with high clamping forces to support long workpieces on lathes. For a quick change, these can also be combined with a steady rest quick-change.



Advantages – Your benefits

- + Precision-lever steady rest for top quality demands**
Allows excellent machining results
- + Highly precise lever kinematics**
High centering and repeat accuracy
- + Serially sealed against chips and air purge connection as a standard**
Ensure higher process reliability and extended maintenance intervals
- + Roller rinsing as standard**
To avoid contamination and chip nesting
- + Optimized lubrication system due to central lubrication**
Easy supply and long lifetime
- + Hydraulic connections at the rear and side of the cylinder**
Easy attachment to almost any machine
- + Integrated safety valve and end position control**
Maximum operating safety
- + Monitoring of the piston position optionally available**
Shorter cycle times and collision protection
- + Compatible with all commercially available steady rests**
Easy exchange of steady rests without any additional special parts
- + All sides of the functional parts are hardened and ground**
Ensures a long service life

Technical data

Description	Clamping range [mm]	Operating pressure [bar]	Max. clamping force [kN]	Centering accuracy [mm]	Repeat accuracy [mm]
THL plus 100	4 – 66	6 – 50	1	< 0.02	< 0.005
THL plus 200	8 – 101	8 – 60	3.5	< 0.02	< 0.005
THL plus 300	12 – 152	8 – 60	10	< 0.04	< 0.007
THL plus 310	20 – 165	8 – 60	10	< 0.04	< 0.007
THL plus 320	50 – 200	8 – 60	10	< 0.04	< 0.007
THL plus 400	35 – 245	8 – 60	15	< 0.05	< 0.01
THL plus 500	50 – 310	8 – 60	15	< 0.06	< 0.01
THL plus 510	85 – 350	8 – 60	15	< 0.06	< 0.01

Function of THL plus

The axially movable oval piston is connected directly to the control cam. The cam segment transmits the force to the two levers and generates a centering movement that is synchronous to the rotational axis of the workpiece.

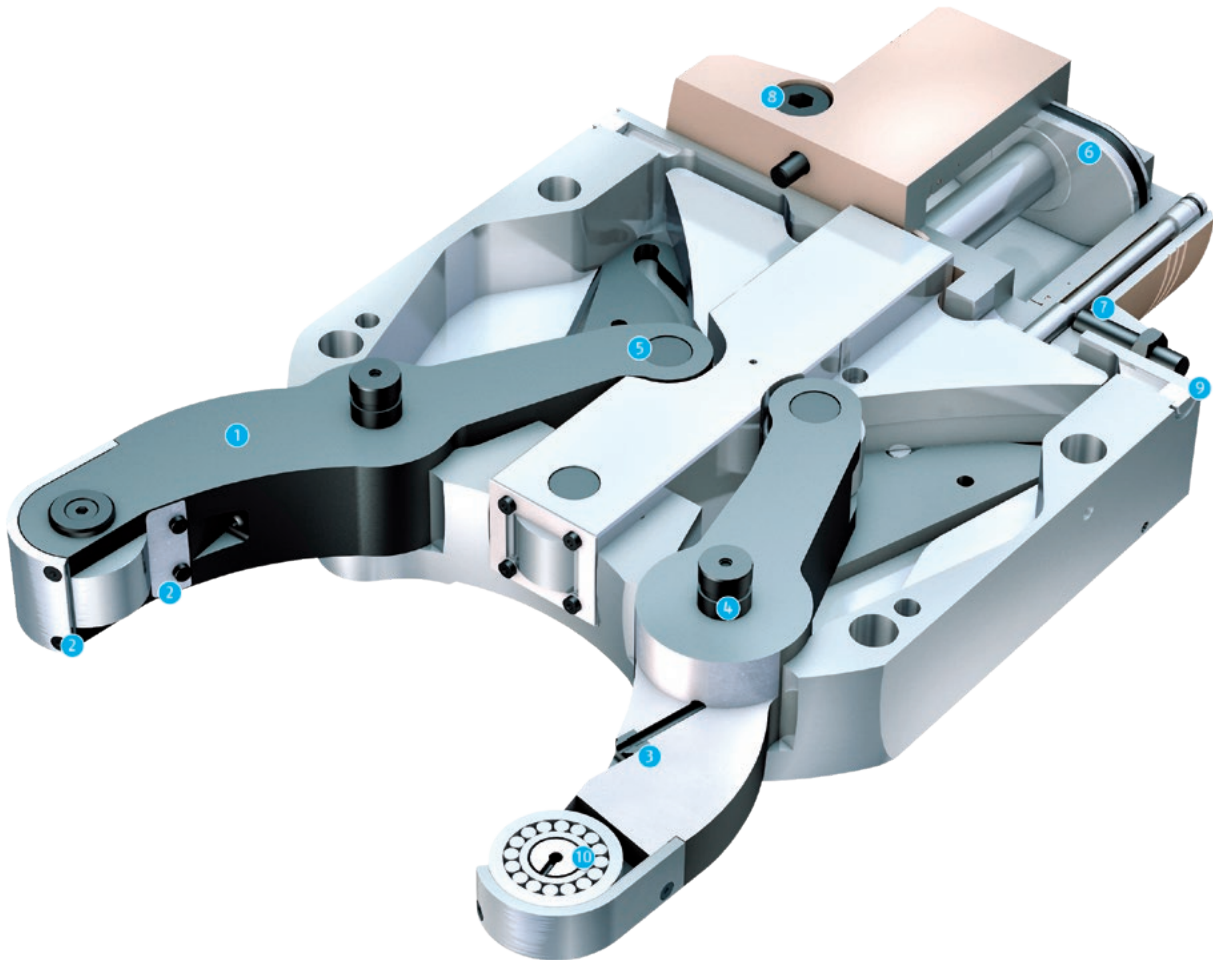

- 1 Lever drive**
Offers constantly high centering and repeat accuracy in operation
- 2 Sealed with double, extremely robust chip protection**
This allows a longer service life at highest precision
- 3 Roller rinsing as standard**
To clean chips from the roller and workpiece for an optimal clamping surface
- 4 Stable lever bearing**
For consistently rigid centering
- 5 Swing-out lever arm**
For more loading space
- 6 Oval piston cylinder**
A slim cylindrical design minimizes interfering contour of the steady rest
- 7 Standard version ready for installation of piston position monitoring**
For monitoring of the end positions or the permanent position of the lever arms
- 8 Safety check valve**
Short-term clamping force maintenance even when the system pressure drops
- 9 Air purge connection**
Minimized dirt entry into the steady rest due to permanent overpressure
- 10 Cylindrical/spherical rollers**
For use as stationary (cylindrical) or traveling/leading steady rest

THL plus standard version

Even the standard THL plus steady rest convinces by many characteristics. This includes a roller rinsing, central lubrication, hydraulic connections laterally and on the back of the cylinder, a very stable chip protection at the rolls, and an air purge connection. For increasing safety, an end position control and a check valve are integrated in the cylinder. Every steady rest is compatible by 100% with the ones of SMW Autoblok



Lateral hydraulic connections

Hydraulic lines can be additionally connected to the cylinder on the side of the THL plus steady rests. This offers a huge advantage in situations with only minimal space at the rear of the unit.

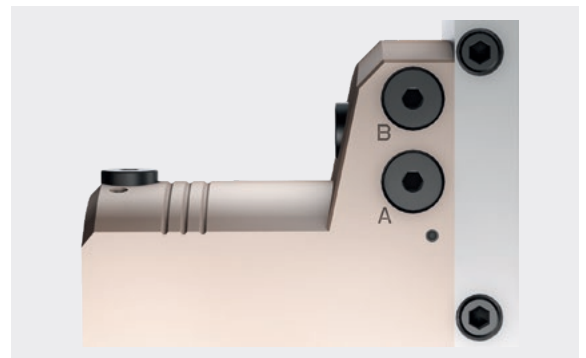

Central lubrication

Steady rests from SCHUNK are also available with central lubrication by default. Via the central lubrication, every movable part is supplied with oil. This allows a very slim design.

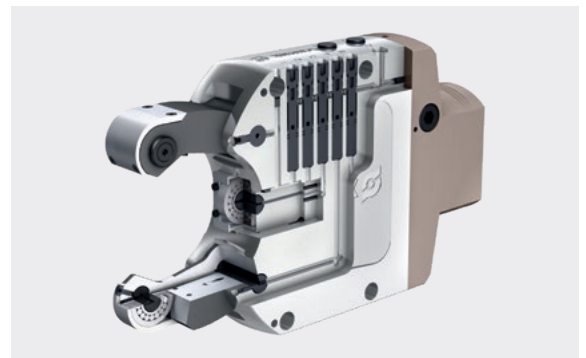

Stroke measuring system

The stroke measuring system enables a continuous position monitoring and a partial opening of the lever arm. This shortens cycle times and protects against collisions. Power supply 24 V; output signal 0...10 V/4...20 mA

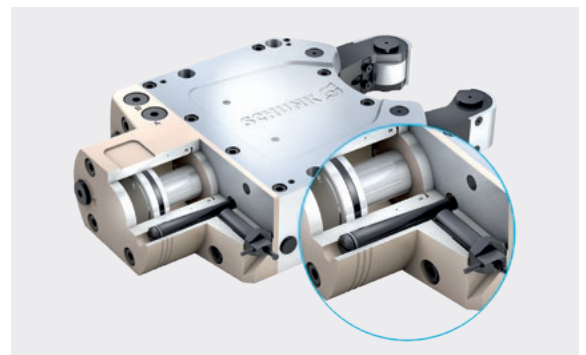

End-position monitoring

Cylinder end position monitoring comes as standard with the ZENTRICO THL plus. A stroke measuring system is available as an option for continuous position monitoring of the lever arm.

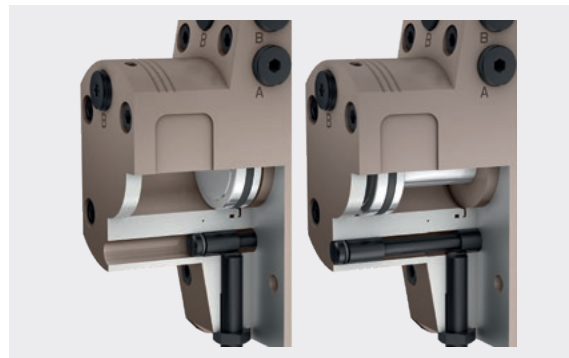

Roller fine adjustment

Eccentric roller pins on the steady rest arms allow quick fine adjustment of the center.

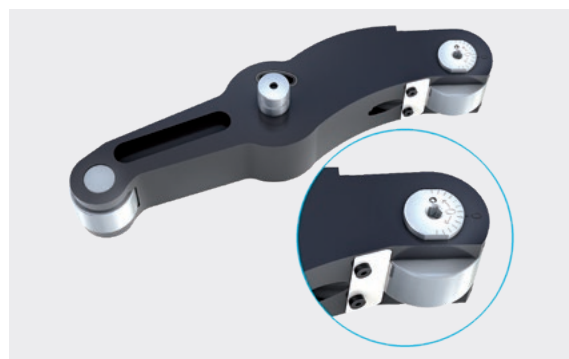

Roller rinsing

ZENTRICO THL plus steady rests come fitted with a roller rinsing system as standard. The jet is aimed between the roller and the workpiece in order to prevent chips from getting jammed there.



Pneumatic version (optional)

A pneumatic version of the ZENTRICO THL plus steady rests is also available as well as the hydraulic variant. These are ideal for the use in handling technology, at stationary workplaces, on conventional lathes and much more.

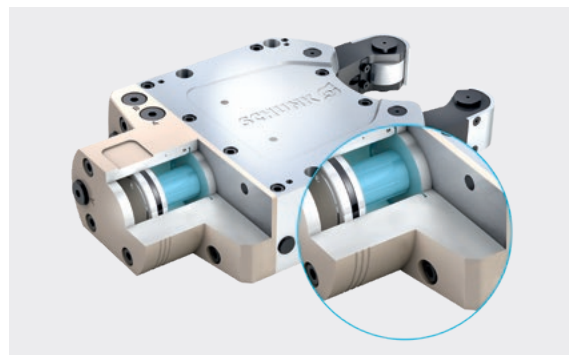

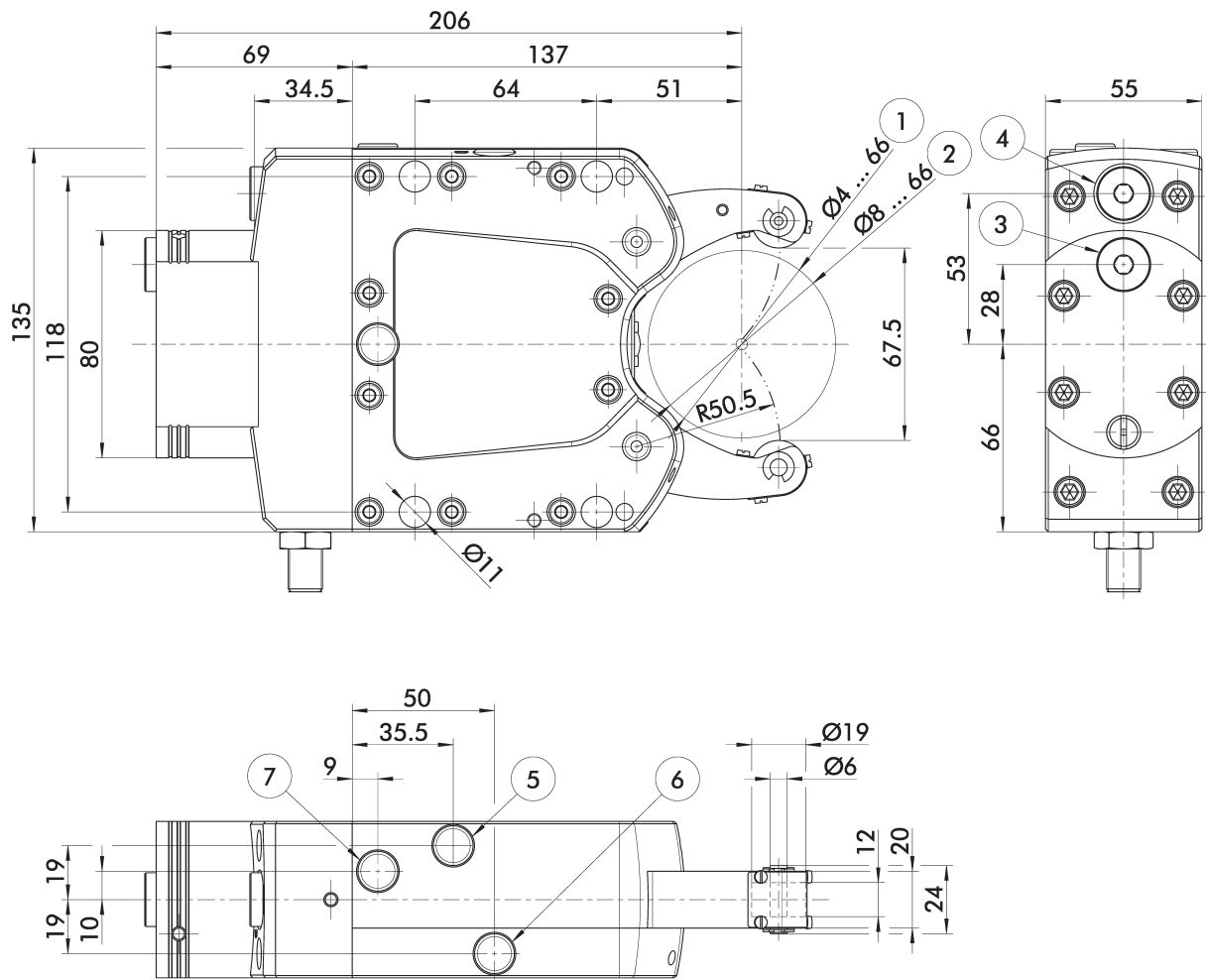

Subject to technical changes.

- ① Clamping range without chip protection
- ② Clamping range with chip protection
- ③ Hydraulics A: G1/4
- ④ Hydraulics B: G1/4
- ⑤ Central lubrication C: G1/8
- ⑥ Flushing D: G1/8
- ⑦ Air purge E: G1/8

Technical data

Description	ID	Type of lubrication	Rollers	Clamping range [mm]	Max. clamping force/roller [kN]	Weight [kg]
THL plus 100 Z-Z	0825111	Central lubrication	cylindrical	4 - 66	1	6.5
THL plus 100 Z-B	0825113	Central lubrication	spherical	4 - 66	1	6.5
THL plus 100 M-Z	0825112	Manual lubrication	cylindrical	4 - 66	1	6.5
THL plus 100 M-B	0825114	Manual lubrication	spherical	4 - 66	1	6.5

Scope of delivery

Steady rest, mounting screws and operating manual; without proximity switch for stroke monitoring

Notes

Maximum workpiece speed

The maximum workpiece speed in relation to the steady rest depends on the permissible circumferential speed of the steady rest rollers. The cutting speed on the clamping diameter is the same as the circumferential speed of the rollers.

Pneumatic steady rest version

The pneumatically operated steady rest version is available on request.

Use of cylindrical rollers

Cylindrical rollers are mainly used in stationary steady rests or applications.

Use of spherical rollers

Spherical rollers are mainly used in trailing or leading steady rests.

Roller rinsing

Coolant or compressed air can be used as the medium for roller rinsing.

Further technical data

Description	Operating pressure [bar]	Centering accuracy [mm]	Repeat accuracy [mm]	Max. circumferential speed [m/min]
THL plus 100	6 - 50	< 0.02	< 0.005	895

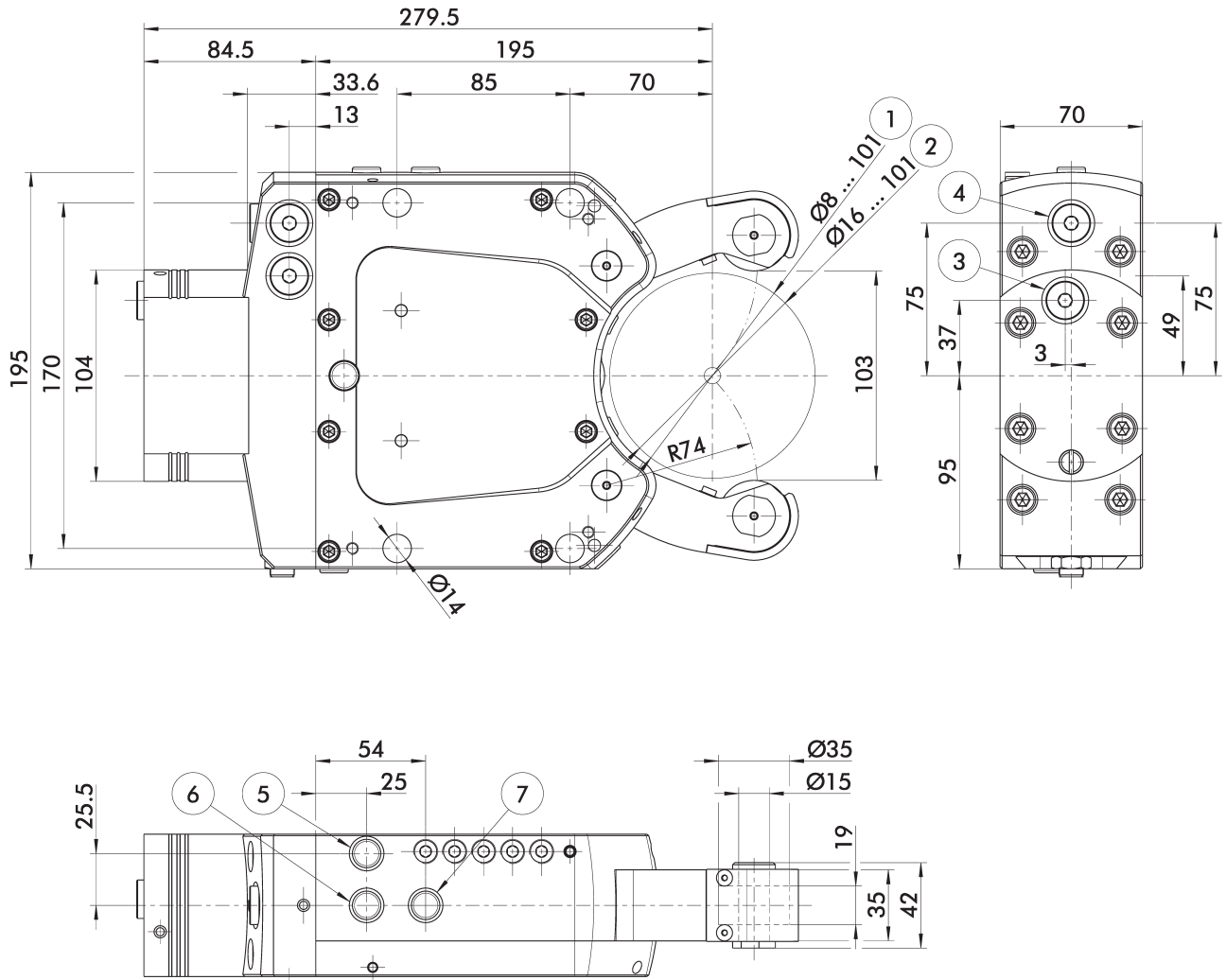

Subject to technical changes.

- | | |
|--|-------------------------------|
| ① Clamping range without chip protection | ⑤ Central lubrication C: G1/8 |
| ② Clamping range with chip protection | ⑥ Flushing D: G1/8 |
| ③ Hydraulics A: G1/4 | ⑦ Air purge E: G1/8 |
| ④ Hydraulics B: G1/4 | |

Technical data

Description	ID	Type of lubrication	Rollers	Clamping range [mm]	Max. clamping force/roller [kN]	Weight [kg]
THL plus 200 Z-Z	0825211	Central lubrication	cylindrical	8 - 101	3.5	15.8
THL plus 200 Z-B	0825213	Central lubrication	spherical	8 - 101	3.5	15.8
THL plus 200 M-Z	0825212	Manual lubrication	cylindrical	8 - 101	3.5	15.8
THL plus 200 M-B	0825214	Manual lubrication	spherical	8 - 101	3.5	15.8

Scope of delivery

Steady rest, mounting screws, eye bolts and operating manual; without proximity switch for stroke monitoring

Notes

Maximum workpiece speed

The maximum workpiece speed in relation to the steady rest depends on the permissible circumferential speed of the steady rest rollers. The cutting speed on the clamping diameter is the same as the circumferential speed of the rollers.

Pneumatic steady rest version

The pneumatically operated steady rest version is available on request.

Use of cylindrical rollers

Cylindrical rollers are mainly used in stationary steady rests or applications.

Use of spherical rollers

Spherical rollers are mainly used in trailing or leading steady rests.

Roller rinsing

Coolant or compressed air can be used as the medium for roller rinsing.

Further technical data

Description	Operating pressure [bar]	Centering accuracy [mm]	Repeat accuracy [mm]	Max. circumferential speed [m/min]
THL plus 200	8 - 60	< 0.02	< 0.005	605

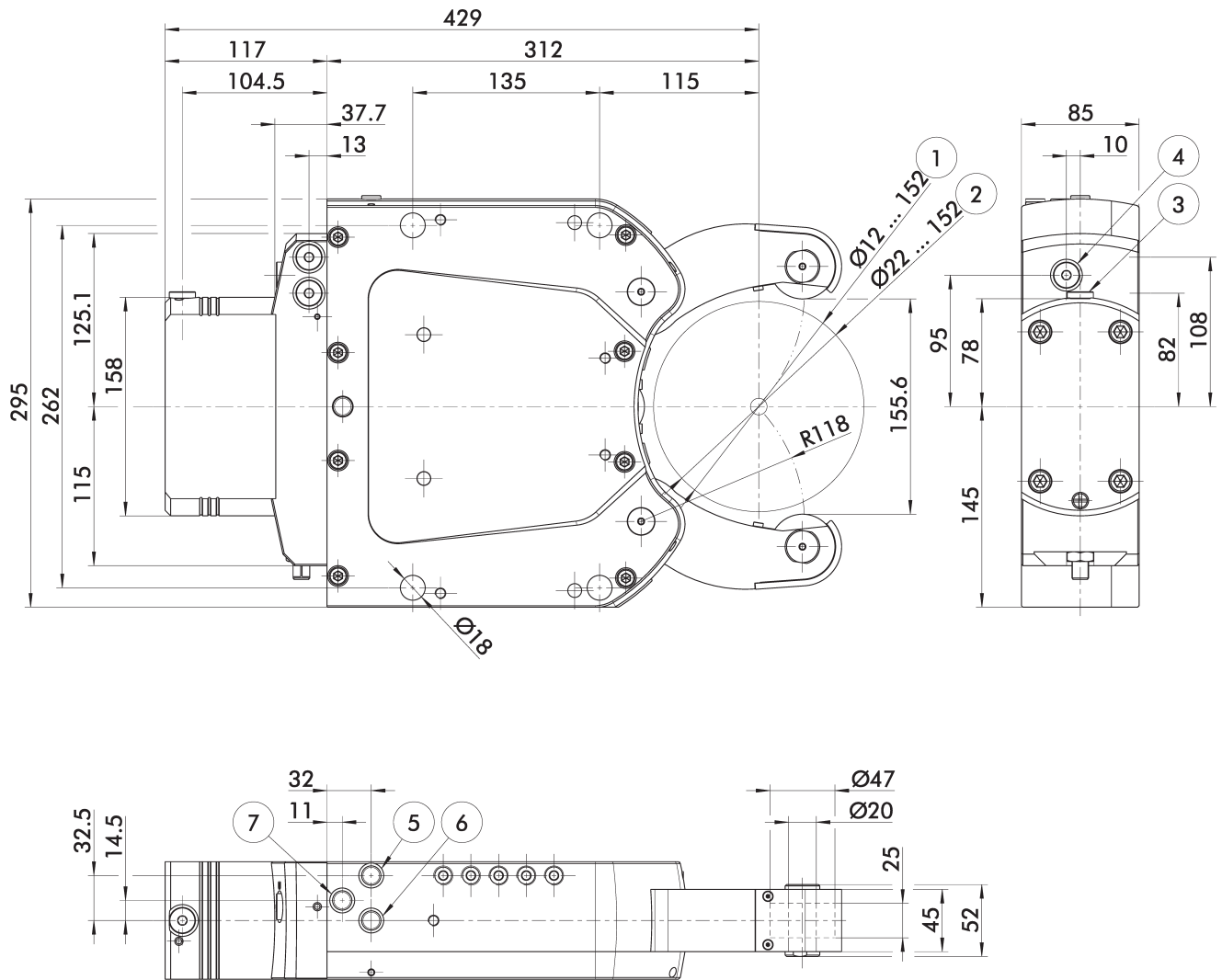

Subject to technical changes.

- | | |
|--|-------------------------------|
| ① Clamping range without chip protection | ⑤ Central lubrication C: G1/8 |
| ② Clamping range with chip protection | ⑥ Flushing D: G1/8 |
| ③ Hydraulics A: G1/4 | ⑦ Air purge E: G1/8 |
| ④ Hydraulics B: G1/4 | |

Technical data

Description	ID	Type of lubrication	Rollers	Clamping range [mm]	Max. clamping force/roller [kN]	Weight [kg]
THL plus 300 Z-Z	0825311	Central lubrication	cylindrical	12 - 152	10	50
THL plus 300 Z-B	0825313	Central lubrication	spherical	12 - 152	10	50
THL plus 300 M-Z	0825312	Manual lubrication	cylindrical	12 - 152	10	50
THL plus 300 M-B	0825314	Manual lubrication	spherical	12 - 152	10	50

Scope of delivery

Steady rest, mounting screws, eye bolts and operating manual; without proximity switch for stroke monitoring

Notes

Maximum workpiece speed

The maximum workpiece speed in relation to the steady rest depends on the permissible circumferential speed of the steady rest rollers. The cutting speed on the clamping diameter is the same as the circumferential speed of the rollers.

Pneumatic steady rest version

The pneumatically operated steady rest version is available on request.

Use of cylindrical rollers

Cylindrical rollers are mainly used in stationary steady rests or applications.

Use of spherical rollers

Spherical rollers are mainly used in trailing or leading steady rests.

Roller rinsing

Coolant or compressed air can be used as the medium for roller rinsing.

Further technical data

Description	Operating pressure [bar]	Centering accuracy [mm]	Repeat accuracy [mm]	Max. circumferential speed [m/min]
THL plus 300	8 - 60	< 0.04	< 0.007	590

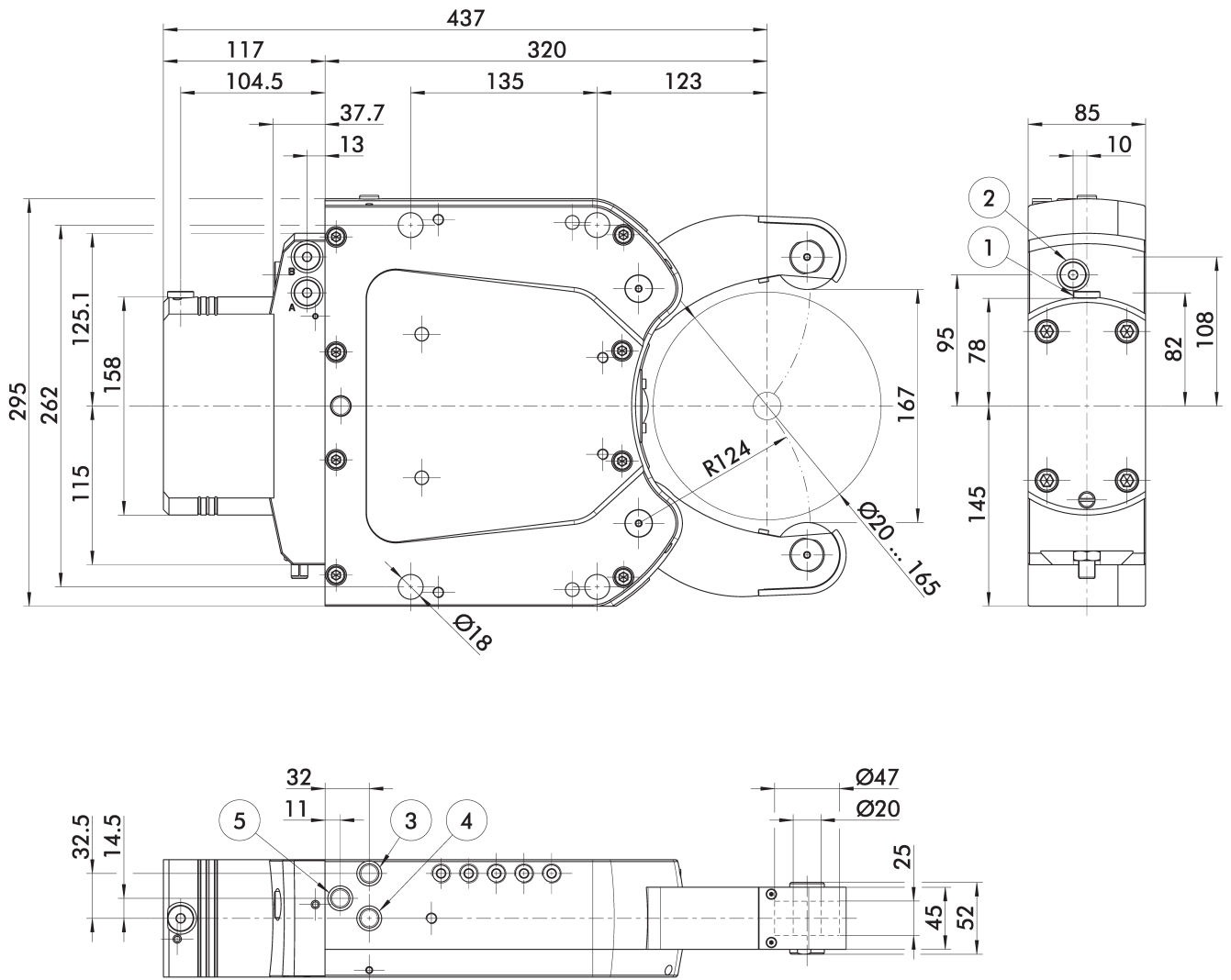

Subject to technical changes.

- ① Hydraulics A: G1/4
- ② Hydraulics B: G1/4
- ③ Central lubrication C: G1/8
- ④ Flushing D: G1/8
- ⑤ Air purge E: G1/8

Technical data

Description	ID	Type of lubrication	Rollers	Clamping range [mm]	Max. clamping force/roller [kN]	Weight [kg]
THL plus 310 Z-Z	0825411	Central lubrication	cylindrical	20 - 165	10	50
THL plus 310 Z-B	0825413	Central lubrication	spherical	20 - 165	10	50
THL plus 310 M-Z	0825412	Manual lubrication	cylindrical	20 - 165	10	50
THL plus 310 M-B	0825414	Manual lubrication	spherical	20 - 165	10	50

Scope of delivery

Steady rest, mounting screws, eye bolts and operating manual; without proximity switch for stroke monitoring

Notes

Maximum workpiece speed

The maximum workpiece speed in relation to the steady rest depends on the permissible circumferential speed of the steady rest rollers. The cutting speed on the clamping diameter is the same as the circumferential speed of the rollers.

Pneumatic steady rest version

The pneumatically operated steady rest version is available on request.

Use of cylindrical rollers

Cylindrical rollers are mainly used in stationary steady rests or applications.

Use of spherical rollers

Spherical rollers are mainly used in trailing or leading steady rests.

Roller rinsing

Coolant or compressed air can be used as the medium for roller rinsing.

Further technical data

Description	Operating pressure [bar]	Centering accuracy [mm]	Repeat accuracy [mm]	Max. circumferential speed [m/min]
THL plus 310	8 - 60	< 0.04	< 0.007	590

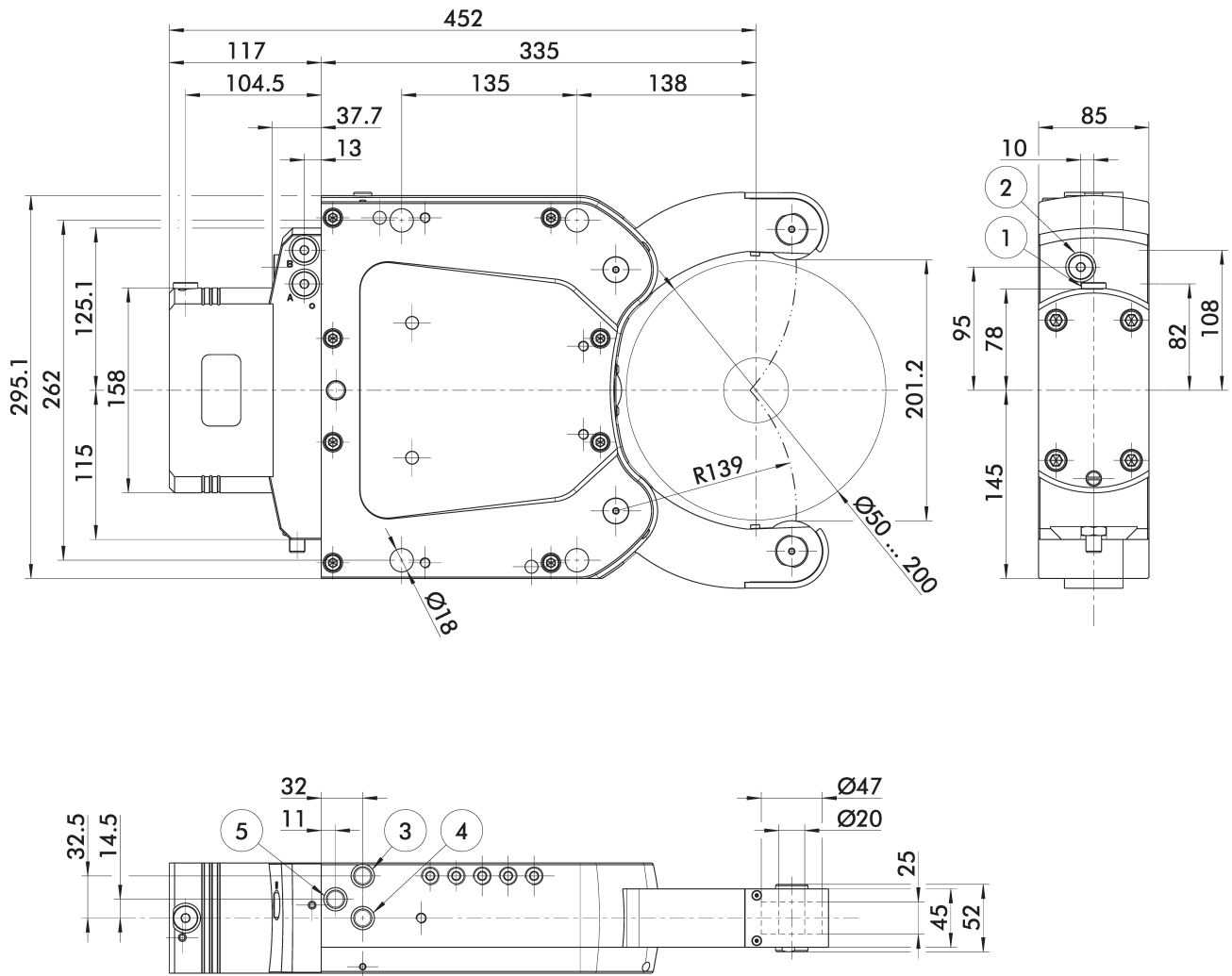

Subject to technical changes.

- ① Hydraulics A: G1/4
- ② Hydraulics B: G1/4
- ③ Central lubrication C: G1/8
- ④ Flushing D: G1/8
- ⑤ Air purge E: G1/8

Technical data

Description	ID	Type of lubrication	Rollers	Clamping range [mm]	Max. clamping force/roller [kN]	Weight [kg]
THL plus 320 Z-Z	0825911	Central lubrication	cylindrical	50 - 200	10	50
THL plus 320 Z-B	0825913	Central lubrication	spherical	50 - 200	10	50
THL plus 320 M-Z	0825912	Manual lubrication	cylindrical	50 - 200	10	50
THL plus 320 M-B	0825914	Manual lubrication	spherical	50 - 200	10	50

Scope of delivery

Steady rest, mounting screws, eye bolts and operating manual; without proximity switch for stroke monitoring

Notes

Maximum workpiece speed

The maximum workpiece speed in relation to the steady rest depends on the permissible circumferential speed of the steady rest rollers. The cutting speed on the clamping diameter is the same as the circumferential speed of the rollers.

Pneumatic steady rest version

The pneumatically operated steady rest version is available on request.

Use of cylindrical rollers

Cylindrical rollers are mainly used in stationary steady rests or applications.

Use of spherical rollers

Spherical rollers are mainly used in trailing or leading steady rests.

Roller rinsing

Coolant or compressed air can be used as the medium for roller rinsing.

Further technical data

Description	Operating pressure [bar]	Centering accuracy [mm]	Repeat accuracy [mm]	Max. circumferential speed [m/min]
THL plus 320	8 - 60	< 0.04	< 0.007	590

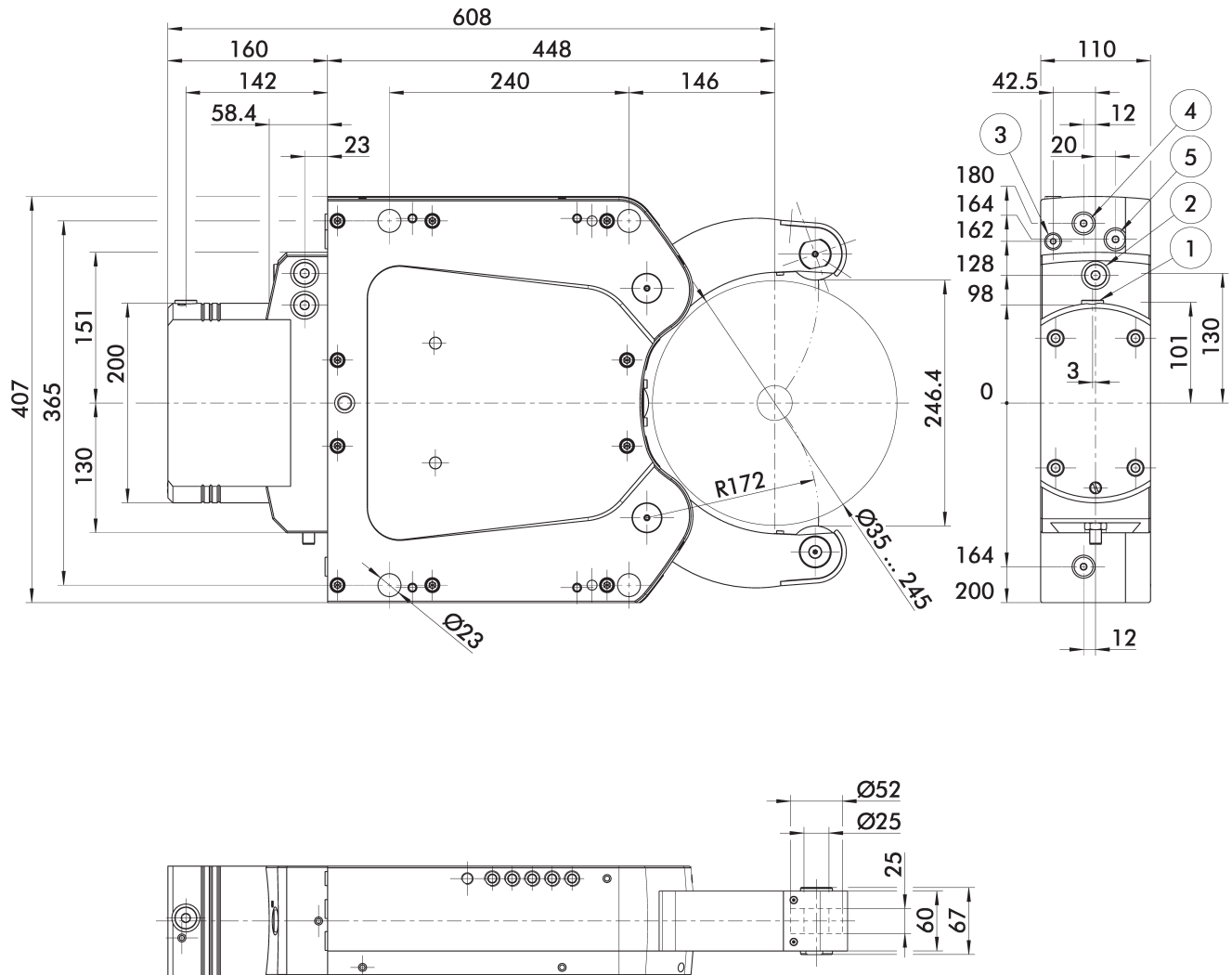

Subject to technical changes.

- ① Hydraulics A: G3/8
- ② Hydraulics B: G3/8
- ③ Central lubrication C: G1/8
- ④ Rinsing D: G1/4
- ⑤ Air purge E: G1/4

Technical data

Description	ID	Type of lubrication	Rollers	Clamping range [mm]	Max. clamping force/roller [kN]	Weight [kg]
THL plus 400 Z-Z	0825511	Central lubrication	cylindrical	35 - 245	15	102
THL plus 400 Z-B	0825513	Central lubrication	spherical	35 - 245	15	102
THL plus 400 M-Z	0825512	Manual lubrication	cylindrical	35 - 245	15	102
THL plus 400 M-B	0825514	Manual lubrication	spherical	35 - 245	15	102

Scope of delivery

Steady rest, mounting screws, eye bolts and operating manual; without proximity switch for stroke monitoring

Notes

Maximum workpiece speed

The maximum workpiece speed in relation to the steady rest depends on the permissible circumferential speed of the steady rest rollers. The cutting speed on the clamping diameter is the same as the circumferential speed of the rollers.

Pneumatic steady rest version

The pneumatically operated steady rest version is available on request.

Use of cylindrical rollers

Cylindrical rollers are mainly used in stationary steady rests or applications.

Use of spherical rollers

Spherical rollers are mainly used in trailing or leading steady rests.

Roller rinsing

Coolant or compressed air can be used as the medium for roller rinsing.

Further technical data

Description	Operating pressure [bar]	Centering accuracy [mm]	Repeat accuracy [mm]	Max. circumferential speed [m/min]
THL plus 400	8 - 60	< 0.05	< 0.01	535

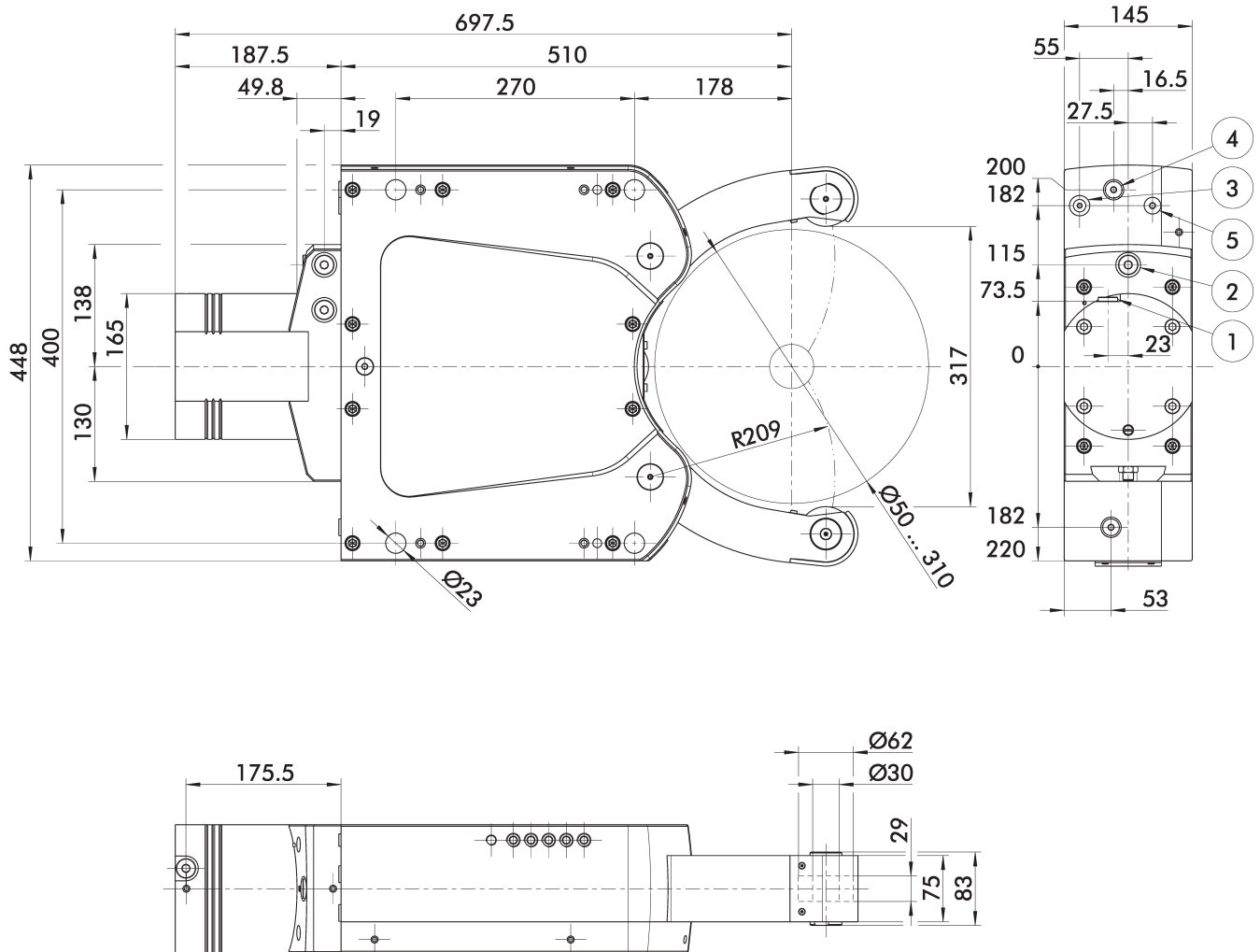

Subject to technical changes.

- ① Hydraulics A: G3/8
- ② Hydraulics B: G3/8
- ③ Central lubrication C: G1/8
- ④ Rinsing D: G1/4
- ⑤ Air purge E: G1/4

Technical data

Description	ID	Type of lubrication	Rollers	Clamping range [mm]	Max. clamping force/roller [kN]	Weight [kg]
THL plus 500 Z-Z	0825611	Central lubrication	cylindrical	50 - 310	15	166
THL plus 500 Z-B	0825613	Central lubrication	spherical	50 - 310	15	166
THL plus 500 M-Z	0825612	Manual lubrication	cylindrical	50 - 310	15	166
THL plus 500 M-B	0825614	Manual lubrication	spherical	50 - 310	15	166

Scope of delivery

Steady rest, mounting screws, eye bolts and operating manual; without proximity switch for stroke monitoring

Notes

Maximum workpiece speed

The maximum workpiece speed in relation to the steady rest depends on the permissible circumferential speed of the steady rest rollers. The cutting speed on the clamping diameter is the same as the circumferential speed of the rollers.

Pneumatic steady rest version

The pneumatically operated steady rest version is available on request.

Use of cylindrical rollers

Cylindrical rollers are mainly used in stationary steady rests or applications.

Use of spherical rollers

Spherical rollers are mainly used in trailing or leading steady rests.

Roller rinsing

Coolant or compressed air can be used as the medium for roller rinsing.

Further technical data

Description	Operating pressure [bar]	Centering accuracy [mm]	Repeat accuracy [mm]	Max. circumferential speed [m/min]
THL plus 500	8 - 60	< 0.06	< 0.01	565

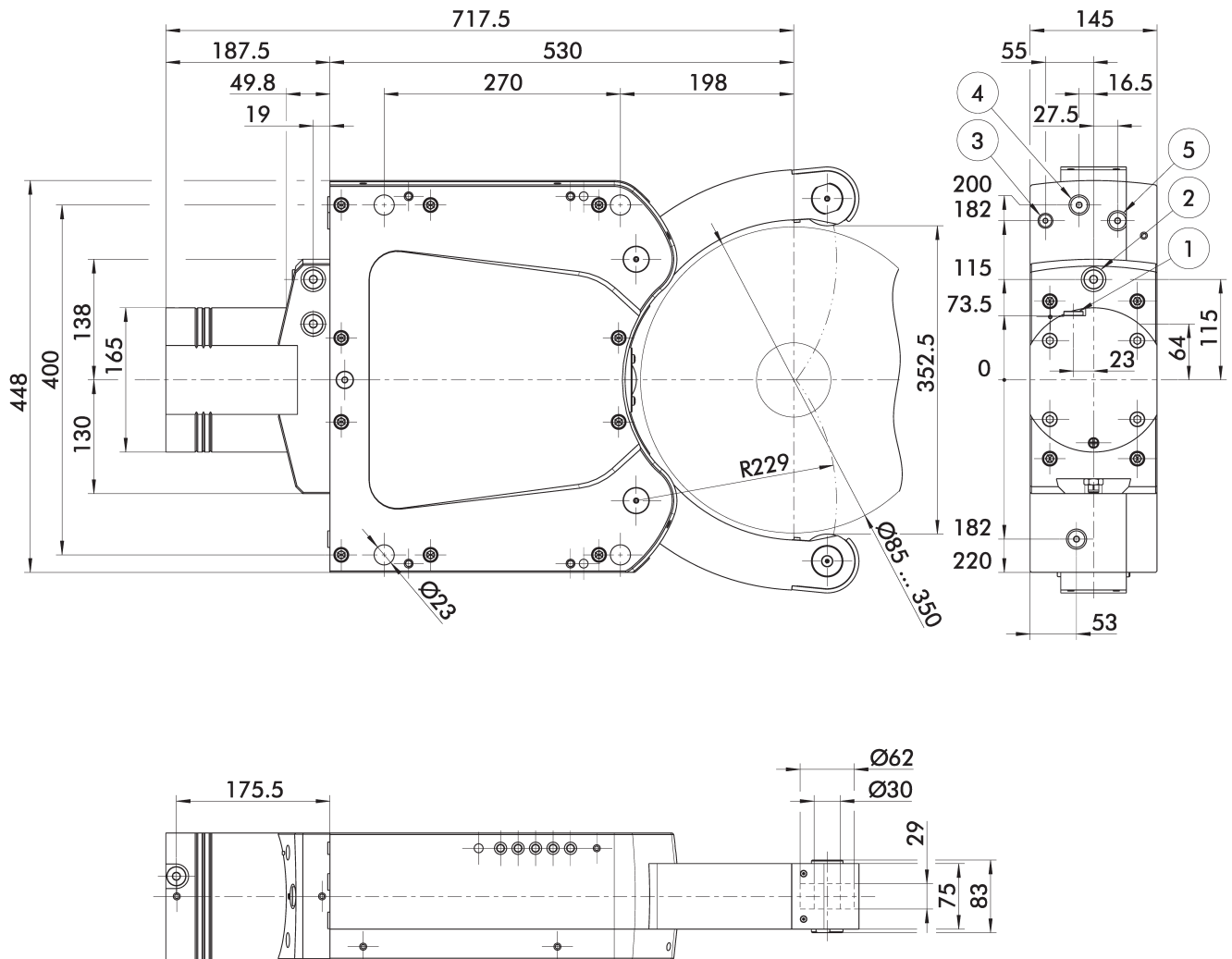

Subject to technical changes.

- ① Hydraulics A: G3/8
- ② Hydraulics B: G3/8
- ③ Central lubrication C: G1/8
- ④ Rinsing D: G1/4
- ⑤ Air purge E: G1/4

Technical data

Description	ID	Type of lubrication	Rollers	Clamping range [mm]	Max. clamping force/roller [kN]	Weight [kg]
THL plus 510 Z-Z	0825711	Central lubrication	cylindrical	85 - 350	15	168
THL plus 510 Z-B	0825713	Central lubrication	spherical	85 - 350	15	168
THL plus 510 M-Z	0825712	Manual lubrication	cylindrical	85 - 350	15	168
THL plus 510 M-B	0825714	Manual lubrication	spherical	85 - 350	15	168

Scope of delivery

Steady rest, mounting screws, eye bolts and operating manual; without proximity switch for stroke monitoring

Notes

Maximum workpiece speed

The maximum workpiece speed in relation to the steady rest depends on the permissible circumferential speed of the steady rest rollers. The cutting speed on the clamping diameter is the same as the circumferential speed of the rollers.

Pneumatic steady rest version

The pneumatically operated steady rest version is available on request.

Use of cylindrical rollers

Cylindrical rollers are mainly used in stationary steady rests or applications.

Use of spherical rollers

Spherical rollers are mainly used in trailing or leading steady rests.

Roller rinsing

Coolant or compressed air can be used as the medium for roller rinsing.

Further technical data

Description	Operating pressure [bar]	Centering accuracy [mm]	Repeat accuracy [mm]	Max. circumferential speed [m/min]
THL plus 510	8 - 60	< 0.06	< 0.01	565

Accessories

Stroke measuring system

Enables a continuous position monitoring and a partial opening of the lever arms.



Suitable for	Description	ID
THL plus 100	APS THL plus 100	0820521
THL plus 200	APS THL plus 200	0820522
THL plus 300	APS THL plus 300	0820523
THL plus 310		
THL plus 320	APS THL plus 310	0820524
THL plus 400	APS THL plus 400	0820525
THL plus 500	APS THL plus 500	0820526
THL plus 510	APS THL plus 510	0820527

Roller fine adjustment

Allows fast fine adjustment of the center via eccentric roll pins at the arms of the steady rest.



Suitable for	Description	ID
THL plus 200	RFV THL plus 200	0820512
THL plus 300	RFV THL plus 300	0820513
THL plus 310		
THL plus 320	RFV THL plus 310	0820514
THL plus 400	RFV THL plus 400	0820515
THL plus 500	RFV THL plus 500	0820516
THL plus 510	RFV THL plus 510	0820517

Grease

LINOMAX plus

High-performance grease as standard for regularly lubricating SCHUNK manual and power lathe chucks and steady rests.



Bundle	Description	ID
Cartridge	LINOMAX plus cartridge	1342585
Can	LINOMAX plus can	1342586
Bucket	LINOMAX plus bucket	1342587

Cylindrical rollers

Sealed rollers for stationary use on the steady rests. Special rollers and coated rollers are available on request.



Suitable for	Description	ID
THL plus 100	LFR-Z 100	0820500
THL plus 200	LFR-Z 200	0820501
THL plus 300		
THL plus 310		
THL plus 320	LFR-Z 300	0820502
THL plus 400	LFR-Z 400	0820503
THL plus 500		
THL plus 510	LFR-Z 500	0820504

Spherical rollers

Sealed rollers for stationary use on travelling (leading) steady rests. Special rollers and coated rollers are available on request.



Suitable for	Description	ID
THL plus 100	LFR-B 100	0820505
THL plus 200	LFR-B 200	0820551
THL plus 300		
THL plus 310		
THL plus 320	LFR-B 300	0820552
THL plus 400	LFR-B 400	0820553
THL plus 500		
THL plus 510	LFR-B 500	0820554

Grease gun

Auxiliary tools for lubrication of all kinds of SCHUNK products. The grease gun can be used for cartridges of all types of SCHUNK grease.



Bundle	Description	ID
Cartridge	Grease gun	9900543



**H.-D. SCHUNK GmbH & Co.
Spanntechnik KG**

Lothringer Str. 23
D-88512 Mengen
Tel. +49-7572-7614-1300
Fax +49-7572-7614-1039
CMM@de.schunk.com
schunk.com